

IISc/SSCU/2020/SP/CR-01/Rev01

Tender Notification for commissioning Class-1000 and Class-10,000 Clean Rooms

Note: The deadlines mentioned in the original tender document posted on 9th April 2020 (IISc/SSCU/2020/SP/CR-01) have been extended, in view of the prevailing covid-19 situation. Modified dates are highlighted in yellow colour.

Tender Opening Date: 9 April 2020

*Revised Closing date for Technical Clarifications/Queries: **1st June 2020** (All technical queries or clarification requests should be sent via email provided below) (previous deadline was 27th April 2020)*

*Technical Clarification Meeting: **8th June 2020** (time and place to be intimated for vendors who send an expression of interest via Email)*

*Revised Tender Closing Date: **30th June 2020** (previous tender closing date: 11 May 2020)*

The tender notification concerns the installation and commissioning of class-1000 and class-10000 clean room sections in the Chemical Sciences Division at the Indian Institute of Science, Bangalore. The commissioning also includes certain equipment as given in the specifications. In case, any equipment is sourced from foreign vendors and delivered directly to IISc, please quote on C.I.P. Bangalore basis (by **Air Freight** only). Your quotation should clearly indicate the terms of delivery, installation, delivery and installation schedule, estimated date for commissioning and payment terms. The tender should be submitted in two separate sealed envelopes - one containing the technical bid and the other containing the commercial bid, both of which should reach us, duly signed on or before **30th June 2020**.

The bids should be addressed to:

*The Chairman,
Solid State and Structural Chemistry Unit
Indian Institute of Science (IISc)
Bengaluru, India - 560012.*

The sealed bids should be sent to:

*Prof. Satish Patil
Solid State and Structural Chemistry Unit
Indian Institute of Science (IISc)
Bengaluru, India - 560012.
Ph: +91-80-2293-2651
email: spatil@iisc.ac.in*

Emails regarding any technical clarifications/queries should be sent to:

spatil@iisc.ac.in and phani@iisc.ac.in

Please enclose a technical compliance statement along with the technical bid.

Technical Specifications and Requirements

I. Broad Requirements and Usage

We are seeking to install two state-of-the-art clean room facilities where one is a Class-1000 clean room and the other a Class-10000 clean room section with related accessories as mentioned in this document. The clean rooms are intended for deposition of metal and metal oxide thin films, thin films of organic materials, processing of substrates and device fabrication using photolithography under a controlled environment. Therefore, the following broad technical criteria are to be met by any quotation submitted under this tender notice:

- I.1.* The construction of clean room spaces must meet standard cleanroom specifications in addition to the specifications mentioned in this tender document.
- I.2.* The clean rooms must maintain air quality, temperature and humidity specifications under normal usage with up to 5 users working simultaneously in addition to the specified equipment load.
- I.3.* Installation should be modular to facilitate any changes that might be needed to accommodate new equipment in the future.
- I.4.* User training on basic maintenance and troubleshooting must be provided.
- I.5.* Materials used in the construction of clean room, fume hoods and clean room benches including but not limited to polypropylene should all meet the ANSI 4910 standard for clean room materials. Specifically, the fire propagation index (FPI) should be below 6 and smoke development index (SDI) should be below 0.4. ***Test data and specifications sheets should be provided along with the technical bid. If material(s) with FPI and/or SDI above these limits are being quoted, data from parallel panel fire test with all necessary data must be submitted along with the technical bid. Bids without these metrics will be deemed to be technically non-compliant.***
- I.6.* *The vendor must use components/parts manufactured by the list of approved manufacturers only. If equivalent components from manufacturers that are not in the approved list are to be used, additional documentation providing enough evidence that all technical specifications are met should be enclosed along with the technical bid.*
- I.7.* The specifications/numbers/data provided in this technical document may not contain all details of design and installation/commissioning of cleanrooms and its utilities at IISc. The vendors should treat the specified quantities/numbers/data for various segments of the cleanroom and utility as a guideline to initiate their calculations. The vendors are supposed to provide IISc with an accurate estimate of each and every component related to the cleanroom and its utility during their bid submittal.
- I.8.* Suitable clean room layout drawings should be provided along with the technical bid.

II. Specifications and Requirements for the Class-1000 Clean Room Section

II.1. Layout and Construction

II.1.1. Floor plan: Total Area: ~25 sq. m.

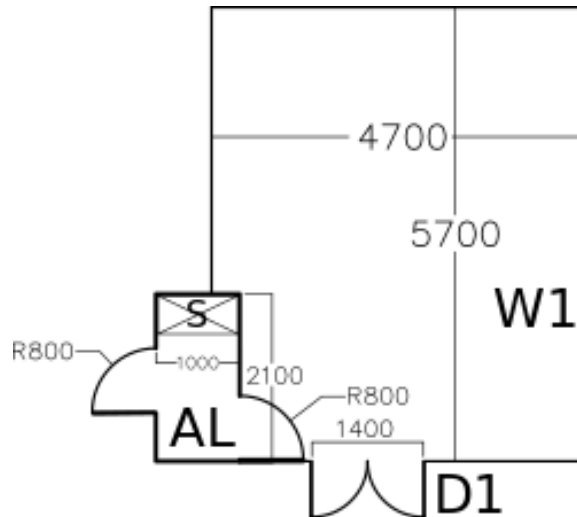

Figure 1: Cleanroom-1000 floor plan

- II.1.2. **Wall panels:** The wall paneling must be modular, interlocking type and double skinned with both sides powder coated (class-1000 clean room grade). The panels must have built-in air raisers for extracting return air from the cleanroom. The panels must be at least 100 mm in thickness with polyurethane foam (PUF) infilling with a density greater than or equal to 40 kg/m³. The panels must be reinforced along the periphery. Panels must be mounted and secured on suitable tracks. All joints must be sealed with cleanroom compatible neutral grade silicone sealant. All cutouts must be covered with a suitable track.
- II.1.3. **Ceiling:** The cleanroom ceiling must be at a height of 2700 mm or higher from the floor of the cleanroom. The ceiling height of the lab space housing the Class-1000 cleanroom is ~5250 mm. The ceiling paneling must be modular, and double skinned with both sheets powder coated (class-1000 clean room grade). The panels must be at least 50 mm thick with PUF infilling with a density greater than or equal to 40 kg/m³. The panels must be reinforced along the periphery and mounted on suitable tracks. All joints must be sealed with cleanroom compatible neutral grade silicone sealant. All cutouts must be covered with a suitable track.
- II.1.4. **Surface Finish of Negative Pressurized Plenum:** The inner surface of the true ceiling & wall surface above false ceiling (negative pressurized plenum) shall be provided with cladding of 25 mm/50 mm thick cleanroom compatible cladding material having PUF as infill material.
- II.1.5. **Flooring:** The flooring must be anti-skid, hard wearing and electrostatic dissipative and sufficiently thick and dense to bear the weight of equipment.
- II.1.6. **Covings:** PVC covings must be installed at corner joints of (a) Wall – Wall (b) Wall – Ceiling (c) Wall – Floor. All 3D corners must be installed and must be covered by 3D pieces. All covings must be ESD proof.
- II.1.7. **Doors:** One double shutter door (D1) with a width of 1400 mm (each door 700 mm wide) and 2400 mm in height. The doors are meant to be used as emergency

exits and for equipment movement. The doors must be at least 44 mm in thickness with PUF infill (density > 40 kg/m³). The doors must be flush with the panels when closed and must be fixed to the door frames with concealed stainless-steel double bearing butt-hinges as per BS7352 specification. The doors must be provided with all required ancillaries like door closer, lock and key, D-handle, push plate, tower bolt all made of SS. Each door must be provided with a view glass of size 0.4m x 0.4m. All doors must open to the outside of the cleanroom and must be provided with a panic bar so that the doors can be quickly opened to exit the cleanroom in case of an emergency.

- II.1.8. **Access System:** An RFID-based access system should be included. This should be configurable with existing ID cards. The details of the ID cards will be provided at the time of installation.
- II.1.9. **Window modules:** Windows and door vision panels should be formed from double glazed toughened glass composite modules. One view panel (marked as W1 in Figure 1) of size 900x900 mm shall be provided in the wall panels. View panel glass shall be at least 5 mm in thickness. View panels shall be fixed flush to both faces of wall panels. No crevices/joints/sloped profiles should be used for fixing the glass. This requirement is to avoid particle contamination and dust accumulation. All windows and door vision panels must have a UV-filtering coating (specification sheets/data sheets for the UV filters must be provided).
- II.1.10. One number safety eye shower must be provided inside the cleanroom at a suitable location.
- II.1.11. A positive pressure airlock (marked as AL in Figure 1) is to be provided at the cleanroom entrance. This is also to serve as a gowning area. It must be provided with a fan filter unit to maintain a clean atmosphere inside. The airlock must have interlocking doors so that only one door can be opened at a time. The locks must automatically disable when any emergency alarm in the cleanroom is triggered to enable quick evacuation of personnel. The airlock must be provided with necessary cabinet(s) (marked as S in Figure 1) for storing clean room gowns, hairnets, shoe covers, and other accessories.
- II.1.12. This clean room space must include necessary lighting and electrical panels and distribution points, an air handling unit, an acid-base workstation, a substrate processing and solvent workstation and a deionized water system.

II.2. Lighting and Electrical installations in Class-1000 cleanroom section

- II.2.1. Sufficient ultra-violet-filtered, ceiling mounted LED lighting must be provided through-out the cleanroom. All radiation below 500nm must be blocked by the UV filters in the lighting systems. The lighting must be sufficient to provide 400 lux or greater illumination at 1 m from the cleanroom floor at all points inside the cleanroom. The illumination intensity must be demonstrated before commissioning. The lighting controls must be provided at user accessible locations inside the cleanroom near the user access door. The necessary fittings, wiring from distribution board and switches must also be supplied and installed.
- II.2.2. In addition, UV filter films must be applied at all points where light containing sub 500nm radiation might enter the cleanroom e.g. windows and door vision panels.
- II.2.3. 32 numbers of 5/15A single-phase power points and 4 numbers of 3-phase 32A power points should be provided. These power points must be distributed over 5

lines each equipped with a suitable rated terminal circuit breaker (MCBs). Each of the power point must be labelled to indicate the line it is connected to. The MCBs are to be housed in a separate power distribution board. The distribution board must be constructed out of cleanroom compatible materials.

- II.2.4. All motors and switchgears required for various items shall generally be all electric. Motors shall be suitable for 3 Phase, 50 Hz, 415 volts A.C. supply. The AC supply variability could be between +/- 10%. Therefore, the motors should withstand such load fluctuations. If the motor input is not suitable for power fluctuations, a voltage stabilizer should be provided. Electrical supply from electrical panel to respective AHUs/Condensing Units/Dehumidifier must use armored cables. Any underground cabling must be steel armored.
- II.2.5. All electrical wiring/cabling must be fire retardant and of a reputed make and must be sufficiently rated to handle the specified loads. The wiring/cabling must be routed through fire-retardant electrical conduits. Inside the clean room, the cables must be routed through appropriately sized fire-retardant PVC dado with partitions for routing cables and positioning power points separately.
- II.2.6. A suitably rated electrical panel must be provided and cables from AHU and other electrical units must be terminated at the panel. Copper lugs should be insulated for cable termination. All bus bars in the panel should be of copper. Incoming cabling termination at the electrical panel will be provided by IISc.
- II.2.7. All wires/cables must be color coded according to applicable electrical wiring standards. The wires must be labelled appropriately at the terminals. All electrical wiring diagrams/drawings with corresponding labels must be provided with installation documents.

II.3. Installation of gas lines and accessories for Class-1000 cleanroom

- II.3.1. Gas distribution lines, one each for ultra-high pure Nitrogen, ultra-high pure Oxygen and ultra-high pure Argon must be installed. Each gas line must be plumbed from a gas storage bay outside the cleanroom and terminated at a gas manifold inside the cleanroom with at least 4 output lines. The cost of fittings and piping up to 5 meters per distribution line is to be included in the scope of this work. As an option, the vendor must quote cost for laying any additional length of gas lines on a per foot basis. However, the vendor is advised to visit the site and make appropriate measurements/calculations. Failure to do so will not absolve the vendor of responsibility to do the work as specified in agreement.
- II.3.2. As an option, the vendor must quote for supply and installation of components for connecting the gas lines to gas cylinders described as follows. Each gas line must have a flexible high-pressure SS hose (SS316L core and SS wire braided outer layer) connected with a bull nose appropriate for each gas mentioned in section II.3.1. The bull nose must be connected to the hose through a non-return valve. The SS hose must be connected to a gas pressure regulator through a shut-off valve. The regulator must be of all stainless-steel construction capable of handling inlet pressure of 200 bar. Outlet pressure must be adjustable over 0-15 bar. A sample configuration is shown in figure 2. The regulator must be of barstock type with SS316L or Hastelloy diaphragm. All sealing materials used inside the regulators/shut-off valves must be compatible with the particular gas type and purity grades. The vendor must attach datasheets/specifications for the

- same. Gas regulators and other components should be provided from the list of preferred OEMs, where provided.
- II.3.3. Plumbing for nitrogen gas lines from the gas manifolds to the cleanroom wet chemical stations 1 and 2 described in sections II.5 and II.6 must be included in the scope of this work.
 - II.3.4. Gas tubing must be supported on channel mounted tubing support with provision to carry a total of 5 lines.
 - II.3.5. Any unconnected lines must be appropriately terminated with suitable fittings.
 - II.3.6. All support structures and fittings inside the cleanroom must be resistant to acids and common organic solvents.
 - II.3.7. All gas lines and accessories must be constructed out of high quality SS316L and must be of a reputed make. Orbital welding or VCR type metal-metal seals are preferred for all joints and fittings on the gas distribution lines. Compression type seals are also acceptable, if compatible with clean room specifications. The RMS roughness of the inner body of the SS tubing must be compatible with the gas type as mentioned in II.3.1.
 - II.3.8. Shut off valves are to be provided for every point of use connection.
 - II.3.9. All gas lines must be leak-checked after installation and appropriate connections.
 - II.3.10. All gas lines must be labelled at appropriate intervals with clearly visible fade-proof labels easily readable by the user. The vendor must also provide drawings of the final gas plumbing layout.

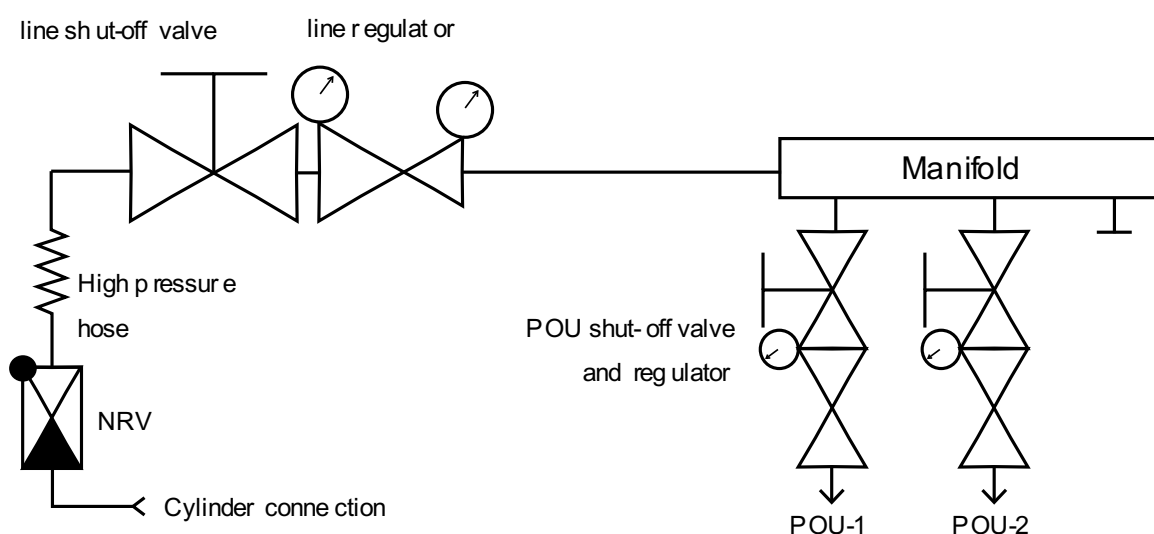

Figure 2: Sample gas line configuration

II.4. Air Handling Unit and related specifications for Class-1000 cleanroom section

- II.4.1. A dedicated recirculating-type Air handling unit/HVAC system must be provided for the class-1000 cleanroom
- II.4.2. The HVAC system must be designed to maintain the class-1000 clean room conditions as specified below:
 - 1) Air purity: Particulate concentration of less than 1000 particles of size $<0.5 \mu\text{m}$ per cubic feet (Class-1000) according to ISO 14644,

- 2) Room temperature of 22 ± 2 °C
- 3) Relative humidity levels (RH) of $45 \pm 5\%$
- 4) Differential pressure of 15-20 Pa
- 5) Number of users: **five** users
- 6) Estimated equipment load: 6 kW
- 7) Air flow pattern: Downward unidirectional
- 8) Supply air plenum: Negative pressure plenum type airflow using FFU with suitable HEPA filters
- 9) Supply air change rate: 130 air changes per hour
- 10) Supply air velocity: minimum 90 fpm $\pm 20\%$ (0.45 mps $\pm 20\%$)
- 11) Filter coverage: minimum 30%
- 12) Fresh air changes per hour: 3

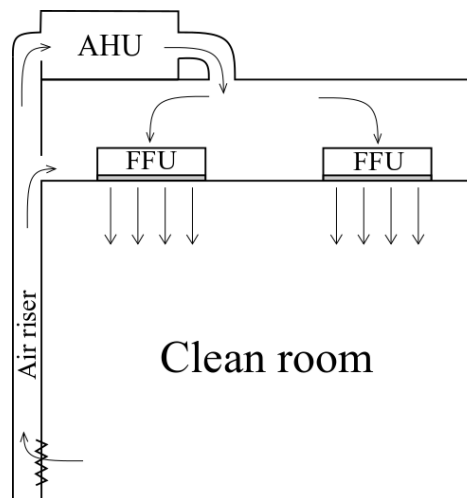

Figure 3: Cleanroom airflow schematic

- II.4.3. Modular fan filter units (FFUs) mounted on the cleanroom ceiling should filter the air and blow it into the cleanroom through suitably rated HEPA filters to remove particulate contaminants. The return air should be extracted through side extractors near the floor through the enclosed air-raisers inside the wall panels. Part of the return air should be conditioned and filtered in the Air Handling Unit (AHU). Air should pass through a series of pre/fine filters, cooling/reheating coils before being supplied to the FFU through corrosion resistant, insulated ducting. This suggested airflow schematic is shown in figure 3. Any other airflow designs, if submitted, must be technically justified.
- II.4.4. Air Handling Units (AHU) must be designed to meet specifications in II.4.1. Fresh air intake must also take into account the exhaust of the fume hood specified in section II.5. AHU must be fitted with appropriate cooling coils, humidifiers, dehumidifiers, pre-filters etc., as required to maintain air temperature and humidity within specification II.4.1. Condenser unit must have a capacity of 6 TR or greater. Air heater module must also be appropriately rated. Only non-toxic, environment friendly refrigerants (R-407C or equivalent) may be used in the condenser units. Details of the refrigerant must be provided. All refrigerant piping and connectors must be made of copper and suitably insulated.
- II.4.5. Treated fresh air needs to be provided in order to compensate for any losses and to also maintain spatial positive pressure in the cleanroom. Precooling coils with

- suitable pre-filters, volume control dampers (VCDs), mixing box, heaters, mist eliminators etc., should be provided for the fresh air intake of the AHU.
- II.4.6. AHU must be installed on the roof of the building that houses the clean room. Approximate length of the ducting required is about 18 meters. The vendor may specify optional per meter cost for any extra ducting work. However, the vendor is advised to visit the site and make appropriate measurements/calculations. Failure to do so will not absolve the vendor of responsibility to do the work as specified in agreement.
 - II.4.7. Fan filter units (FFU) must be modular in design and must be sourced from a reputed Original Equipment Manufacturer (OEM). Sufficient number of FFUs must be provided to maintain the cleanroom particulate and other specifications (specification II.4.1).
 - II.4.8. All filter units must have HEPA filters manufactured by a reputed OEM. The filters must remove particulates bigger than 0.3 micron with 99.997% or greater efficiency (vendor must provide manufacturer specifications or supporting data). The quote must include details of the OEM. The filter units must also be equipped with prefilters to remove particulates bigger than 10 microns with 90% or greater efficiency.
 - II.4.9. The FFUs must have variable air flow rate with user controllable fan speed. The minimum flow rate must be 650 cfm. The fan filter units must produce less than 55 dB of noise measured inside the cleanroom at a distance of 750 mm from the filter face. Vibration levels must be less than 25 microns.
 - II.4.10. All unit enclosures must have a double skinned corrosion resistant enclosure with a thermal and acoustic insulating infill i.e. PUF of sufficient density. Enclosures must be provided with fire and smoke detectors and alarms, inspection doors and necessary inspection lighting. All mounts and frames for the indoor/outdoor units must be painted, be corrosion resistant and must be suitably padded to minimize vibration and noise.
 - II.4.11. All ducting must be fabricated according to the latest SMACNA standards and must be cleanroom compatible. Air handling ducts and ducting joints must be made of corrosion resistant material that is resistant to any acid vapors and must have a minimum thickness of 24 gauge (~0.635mm) conforming to the latest SMACNA and cleanroom standards. The clause regarding acid resistance may be relaxed for portions, that the vendor has sufficient reason to believe, would never be exposed to acid vapors. However, the vendor must provide suitable drawings/documentation to support this. Ducting must be low noise and vibration free. All ducting/joints must be tested for leakage before commissioning and the leakage must be within the limits specified in the latest SMACNA standards.
 - II.4.12. All ducting must be provided with sufficient thickness of insulation. The insulation must be fire retardant and aluminum faced. Provision must be made for internal cleaning of the ducting at appropriate locations.
 - II.4.13. Any grills/diffusers used must be made of extruded anodized aluminum.
 - II.4.14. All clamps/fastenings used for the ducting must be corrosion resistant.
 - II.4.15. Alarms indicating any faults including fire and smoke alarms and alarms for detecting faults in the air handling system must be installed inside the cleanroom to alert users inside the cleanroom in case of any emergencies.
 - II.4.16. An indicator/display unit for clean room temperature, RH and air handling system status along with a gauge showing the differential pressure of the cleanroom must be provided inside the cleanroom.

- II.4.17. A positive pressure airlock (AL), preferably with an air shower, must be provided near Door D1 as discussed in II.1.11. The specifications of the air lock should be consistent with the requirement for maintaining a particle purity required for a class-1000 clean room.

II.5. Specifications for wet chemical station-1 for acids-bases

- II.5.1. Wet chemical station-1 (WCS-1) is meant for wet chemical processing using acids, bases and majorly aqueous solutions.
- II.5.2. WCS-1 should be composed of two parts:
Part 1: 600x900x2400 mm (width x depth x height) fume hood with exhaust.
Part 2: 1200x900x2400 mm (width x depth x height) class-100 clean bench without exhaust.
- II.5.3. WCS-1 must be constructed out of stress relieved high-quality polypropylene sheets of thickness 10 mm or thicker (data regarding residual stress must be provided). Any material being quoted must meet all clean room materials specifications as noted in 1.5. In addition, the material should be compatible with a variety of clean room solvents and photoresist/developer solutions used in a clean room. ***A list of compatible solvents must be given.***
- II.5.4. The fumehood portion of WCS-1 must be provided with a clear transparent height adjustable counter-weight balanced sash made of acid and solvent resistant material that is at least 6mm in thickness. If this is a glass sash, it should be made of toughened laminated glass so that the glass does not shatter and fall to pieces in case of an explosion or breakage.
- II.5.5. The fumehood must have a standard value for face opening at full sash position. The sash opening at full sash position must be provided with the technical bid.
- II.5.6. The fumehood must maintain a face velocity between 90-110 fpm at half sash position. The fume hood exhaust blower must be suitably rated to maintain air flow rates and all ducting must be made of fire-resistant polypropylene. Fire resistance rating should be clearly mentioned. The quote should also include all necessary accessories, fittings for routing the exhaust duct and installation of the blower.
- II.5.7. The fumehood must have a flat 10 mm thick polypropylene worktop with a skirting of 10 mm height and 25 mm width to contain any spills on the worktop and prevent spilling on the floor. The worktop must be at a standard workable height from the cleanroom floor. The worktop height should be provided with the technical bid.
- II.5.8. One de-ionized (DI) water spray gun made of virgin PTFE with anti-static protection must be provided. This should be centrally located between the fume hood section and the clean bench section so that it is accessible for working in both the sections. The piping for the spray gun must be made of high-quality flexible polypropylene and must not leach contaminants into water (provide data or manufacturer specification sheets). When not in use, the piping must retract and be concealed inside the centrally located space between the fume hood and the clean bench. The piping must be sufficiently long so that the spray gun can reach all portions of the work tops in the fume hood and clean bench sections.
- II.5.9. One Nitrogen gun made of virgin PTFE with anti-static protection must be provided. The nitrogen blow gun should be centrally located between the fume hood section and the clean bench section so that it is accessible for working in both the sections. The piping for the nitrogen gun must be flexible, resistant to

acids and common solvents and not outgas or generate particulates (provide specifications or manufacturer data sheet). The piping must have sufficient length to reach all portions of the work tops in the fume hood and the clean bench sections. When not in use, the extra piping must retract and be concealed inside the centrally located space between the fume hood and the clean bench.

- II.5.10. Gas supply lines for nitrogen from gas connection points, which are within 0.5 meters from the fume hood and clean bench, should be included in the scope of work. These gas lines must be constructed from high-quality SS316L grade stainless steel tubing.
- II.5.11. An in-line gas regulator rated to take an inlet pressure of 15 bar or higher and rated to provide an outlet pressure between 0-15 bar with inlet and outlet pressure indication, and a shut-off valve must be provided at an accessible location near the workstation. This in-line gas regulator must be connected to the nitrogen gas distribution line through a shut-off valve on inlet end and to the nitrogen gun or a gas line directly connecting to the nitrogen gun on the outlet end so as to control the pressure of nitrogen. A shut off-valve must be provided on the connection to turn ON or turn OFF nitrogen supply. The pressure regulators are to be SS316 barstock type construction with SS316L or Hastelloy diaphragms. All fittings must be suitable for gas pressure control of noncorrosive or toxic, high purity gases up to grade 5.0 purity (99.999%).
- II.5.12. The part-2 of WCS-1 is a class-100 clean bench. The work area inside the clean bench must be maintained to meet specifications for a class-100 clean bench. Air must be circulated through suitable filters to maintain laminar down flow in the work area. A positive pressure must be maintained inside the work area to prevent contaminants from the room entering the work area. Acid vapors and particulates that may be present in the return air must be scrubbed before recirculation using suitable filters. *Details of suitable scrubbers, their specifications and maintenance schedule should be clearly given along with the technical bid.* The filter modules must use HEPA filters rated at better than 99.99% efficiency in removing particles bigger than 0.3 micron (provide manufacturer specifications or supporting data).
- II.5.13. The clean bench portion must be provided with a clear transparent height adjustable counter-weight balanced sash made of acid and solvent resistant material that is at least 6 mm in thickness. If this is a glass sash, it should be made of toughened laminated glass so that the glass does not shatter and fall to pieces in case of an explosion or breakage.
- II.5.14. The worktop must be made of 10 mm thick high-quality stress relieved perforated polypropylene sheets. A skirting of 10 mm height and 25 width must be provided to prevent any spillage of chemicals on the floor.
- II.5.15. The worktop of the clean bench must house one overflow type DI water bath with dimensions of 200 mm x 200 mm x 300 mm (length x width x depth). The overflow type de-ionized (DI) water bath should be made of stress relieved high quality polypropylene and should be fully integrated into the clean bench. The top of the bath should be lower than the work top by at least 2 inches. The bath must be provided with a lid made of high-quality polypropylene so that it can be closed when not in use.
- II.5.16. When in use, DI water must continuously flow into the DI water bath and overflow out of the tank near the top of the bath. The overflow water must be collected and discharged through a drainpipe, preferably at a user settable flow

rate between 1 *lpm* to 5 *lpm*. A shut-off valve must be provided to close the DI water supply when the bath is not in use. The bath must also be provided with an outlet near the bottom with a shut-off valve for draining the bath for routine cleaning. Both shut-off valves must be electronically controllable, ideally through a touch panel system that also shows the water resistivity and flow rate. The DI water bath is to be connected to the DI water supply system specified in section II.7.

- II.5.17. A main shut-off for DI water supply line and shut-off valves near the clean bench must be provided to shut-off DI water supply if required.
- II.5.18. Lighting with UV-filtering (specification sheets/data sheets for the UV filters must be provided) for an illumination level of 1000 lux or greater at worktop level on all points of the worktops, in the fume hood and the clean bench sections, should be provided.
- II.5.19. Magnehelic gauge of 50 mm of water column capacity to measure the differential pressure at the exhaust plenum box in fume hood portion of the workstation must be provided.
- II.5.20. Magnehelic gauge of 50 mm water column capacity to measure differential pressure inside work area of clean bench portion of the workstation must be provided.
- II.5.21. Three storage cabinet trolleys of 600 mm length each for chemicals/materials storage below the worktop. The trolleys must be made of high-quality polypropylene consistent with the specification in 1.5. One trolley under the fume hood (Part-1) and two trolleys under the clean bench (Part-2) parts of WCS-1 are required.

II.6. *Specifications for wet chemical station-2 for substrate processing using solvents*

- II.6.1. The wet chemical station-2 (WCS-2) is a recirculating type ductless fumehood. Air from the cleanroom is drawn through the front over the work area and passed through suitable activated charcoal and HEPA particulate filters to remove any solvent vapors/particulates before discharging the air back into the cleanroom. The blower used must have sufficient capacity to maintain standard airflow rates. The internal airflow rates must be user controllable and a display must indicate the measured airflow speed. Lighting switches, air flow indicator and airflow controls must be provided on a control panel. *Details of filter specifications and maintenance schedule should be clearly given along with the technical bid.*
- II.6.2. WCS-2 overall dimensions should be 1800 mm x 900 mm x 2400 mm (width x depth x height).
- II.6.3. WCS-2 must be constructed out of stress relieved high-quality polypropylene sheets of thickness 10 mm or thicker (data regarding residual stress must be provided). Any material being quoted must meet all clean room material specifications as noted in I.5. In addition, the material should be compatible with a variety of clean room solvents and photoresist/developer solutions used in a clean room. ***A list of compatible solvents must be given.***
- II.6.4. A clear, transparent height adjustable counter-weight balanced sash made of solvent resistant material that is at least 6 mm in thickness should be provided. If this is a glass sash, it should be made of toughened laminated glass so that the glass does not shatter and fall to pieces in case of an explosion or breakage. The

sash material should be compatible with all clean room solvents similar to the requirements in II.6.2.

- II.6.5. The worktop must be made of 10mm or thicker perforated high-quality polypropylene sheet. A skirting that is 10 mm high and 25 mm wide must be provided at the front of the worktop to contain any spills on the worktop and prevent spilling on the floor. The worktop must house the following 1) SS heated IPA bath 2) Spin coater 3) Hot plate. The worktop must be at a standard workable height from the cleanroom floor. The worktop height being provided must be given with the technical bid.
- II.6.6. One number of isopropyl alcohol (IPA) vapor dryer for cleaning of substrates must be provided in the workstation. Its overall dimensions should be 180 mm x 180 mm x 300 mm (length x width x depth). The material of construction must be 316L grade stainless steel. The bottom half of the dryer serves as the IPA reservoir and must be maintained between 80 °C – 90 °C. Temperature monitoring and control systems are also to be provided. A perforated SS-316L plate placed horizontally at about midway from the bottom separates the space for placing samples for cleaning. The sample space must be at a lower temperature so that IPA vapors from the reservoir condense on the sample and trickle down back into the reservoir. A lid made of 316L grade stainless steel with a handle must be provided to prevent escape of IPA vapors from the bath. The top of the lid (not including the handle) must be flush with the worktop.
- II.6.7. A cooling chamber for allowing IPA to dry after the IPA vapor cleaning step should be provided next to the IPA vapor dryer. The dimensions of this should be 180 mm x 180 mm x 180 mm (length x width x depth). A lid made of 316L grade stainless steel with a handle must be provided. The top of the lid (not including the handle) must be flush with the worktop. A suitable connection to an exhaust line/recirculation line should be provided.
- II.6.8. One number of programmable cleanroom grade spin coater capable of handling up to 6-inch substrates and going up to 10,000 rpm for coating of photoresist must be provided. The spin coater must be from a reputed OEM from the list of approved makes listed in section IV (details to be shared in the quote). All associated accessories including substrate chucks for holding various sized substrates of diameters 5 mm to 4 inch and a vacuum pump with solvent-resistant tubing connecting to the vacuum chuck must be provided.
- II.6.9. One number of cleanroom grade programmable temperature controlled hot plate for baking of photoresist should be provided. The hotplate should preferably be integrated into the worktop. The bid must clearly mention whether a standalone or integrated system is going to be provided. For an integrated hot plate, programming and temperature controls should be integrated into the chemical station control panel. The hot plate must have a heated area of 6-inch x 6-inch and must maintain a temperature within 2% of the set point over the entire heated area (provide supporting data or manufacturer specification sheet). The hotplate must be rated for a maximum temperature of 250 °C. The hot plate must be from a reputed OEM from the list of approved makes listed in section IV (details to be shared in the technical bid). The temperature and ramp rate should be user settable via a temperature controller which also indicates the temperature of the hot plate. The hot plate must have a hinged lid so that the hot plate surface can be covered when not in use.

II.6.10. One Nitrogen gun made of virgin PTFE with anti-static protection must be provided. The nitrogen blow gun should be centrally located so that it can be used throughout the working space of the solvent bench. The piping for the nitrogen gun must be flexible, resistant to common clean room solvents and not outgas or generate particulates (provide specifications or manufacturer data sheet). The piping must have sufficient length to reach all portions of the work top. When not in use, the extra piping must retract and be concealed inside the centrally located space between the fume hood and the clean bench.

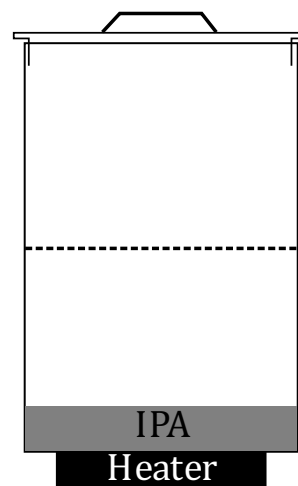

Figure 4: Heated IPA bath schematic – not to scale.

II.6.11. Gas supply lines for nitrogen from gas connection points, which are within 0.5 meters from the solvent workstation, should be included in the scope of work. These gas lines must be constructed from high-quality SS316L grade stainless steel tubing. *Gas supply lines from cylinder storage bay to the gas connection points should be common for this requirement and the requirements in II.5.9. Any gas manifolds should be suitably provided.* All supply lines must be resistant to acids and common organic solvents.

II.6.12. An in-line gas regulator rated to take an inlet pressure of 15 bar or higher and rated to provide an outlet pressure between 0-15 bar with inlet and outlet pressure indication, and a shut-off valve must be provided at an accessible location near the workstation. This in-line gas regulator must be connected to the nitrogen gas distribution line through a shut-off valve on inlet end and to the nitrogen gun or a gas line directly connecting to the nitrogen gun on the outlet end so as to control the pressure of nitrogen. This should be accessible when working at the workstation. A shut-off-valve must be provided on the connection to turn ON or turn OFF nitrogen supply. The pressure regulators are to be SS316 barstock type construction with SS316 or Hastelloy diaphragms. All fittings must for suitable for pressure gas control of noncorrosive or toxic, high purity gases up to grade 5.0 purity (99.999%).

II.6.13. Lighting with UV-filtering (specification sheets/data sheets for the UV filters must be provided) for an illumination level of greater than 1000 lux at worktop level on all points of worktop inside the workstation should be provided.

II.6.14. Magnehelic gauge of 50 mm of water column capacity to measure the differential pressure inside the working area of the workstation must be provided.

II.6.15. At least two storage cabinets of at least 600 mm length each for chemicals/materials storage under the work top must be provided. At least one of the storage cabinets must be a 30-minute fire rated flammable materials storage cabinet rated to contain any fires for at least 30 minutes.

II.6.16. A separate common polypropylene sink of size 450 x 400 mm with a drying area must be provided. It must have a polypropylene gooseneck with a tap and connected to the DI water supply line. The drain of the sink must be piped into the building drainage duct.

II.7. Specifications for deionized water system

- II.7.1. A de-ionized water system consisting of a generation and storage system for generating and storing Type-I (resistivity $\geq 18 \text{ M}\Omega\text{-cm}$) and Type-II water (resistivity $\geq 1 \text{ M}\Omega\text{-cm}$) should be provided. In addition to the resistivity metrics, the DI water system should comply with all Class-1000 clean room specifications. The vendor must design the system to meet all specifications and share the detailed calculations and plant design details along with the quote.
- II.7.2. The DI water plant must be designed to support usage of upto 300 liters/day of Type-II water and upto 100 liters/day of Type-I water with peak usage of 10liters/minute for Type-I water and 10liters/minute for Type-II water (this does not include the usage by the Type-I water generator). The Type-II water generated is to be stored in a storage tank of suitable capacity. The water tank should be made of clean room grade polypropylene. The system must be equipped with an automatic cut-off to stop water generation once the storage tank is full. The Type-II water is to be used as feed water for the Type-I water system.
- II.7.3. The DI water plant along with the storage tank is to be installed in the utility area behind the lab space housing the cleanroom. The plumbing of Type-I water and Type-II water system to the respective distribution lines inside the cleanroom is to be included in the scope of the work. The vendor is advised to visit the site and make appropriate measurements/calculations regarding the length of piping required. Failure to do so will not absolve the vendor of responsibility to do the work as specified in agreement.
- II.7.4. The Type-II water distribution system is to be connected to the POU - DI water bath in wet chemical station-2 (section II.6) and must provide water at the specified flow rate. Type-I water distribution system is to be connected to POU spray gun installed in wet chemical station-1 (section II.5) and must provide water at 10 liters per minute at an output pressure of 1 bar at the spray gun outlet.
- II.7.5. The Type-I water system must continuously recirculate the water to provide constant fluid flow and eliminate dead legs to POU.
- II.7.6. Water quality monitors must be provided for live monitoring of the Type-I and Type-II water quality from the system. Resistivity sensors and display of measured resistivity value must be included.
- II.7.7. The feed water is municipal supply water/borewell water or a mixture of the two. The feed water quality and pressure may vary. The vendor must provide appropriate pre-treatment/filter systems.
- II.7.8. Wastewater, if any, from the Type-I and Type-II systems should be connected to the building drain.
- II.7.9. The vendor must label all water supply lines with fade-proof easily readable labels at appropriate locations and must provide drawings and documentation of the final water plumbing layout.
- II.7.10. All electrical wiring and power points required for powering the DI plant is to be included in the scope of this work and must be done according to standards specified in section II.2.

III. Specifications and Requirements for the Class-10000 Clean Room Section

III.1 Layout and Construction

III.1.1. **Floor plan:** Total Area: ~42 sq. m as in Figure 5.

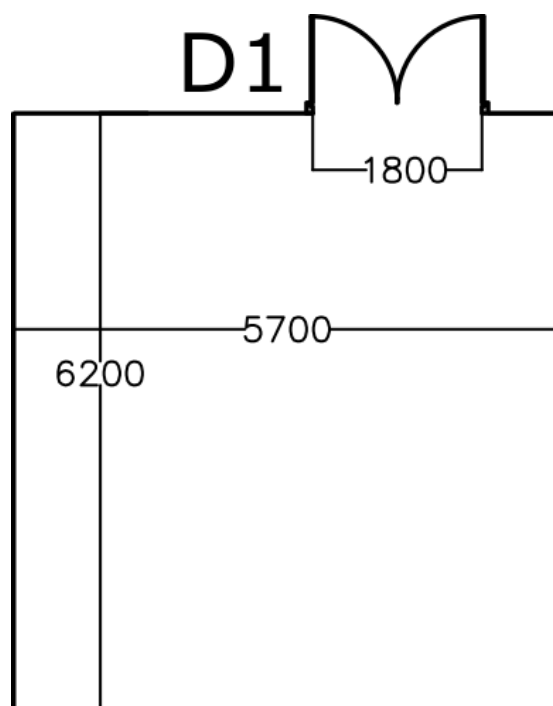

Figure 5: Class-10000 cleanroom floor plan

- III.1.2. **Wall panels:** The wall paneling must be modular, interlocking type and double skinned with both sides powder coated (class-10000 clean room grade). The panels must have built-in air raisers for extracting return air from the cleanroom. The panels must be at least 100 mm in thickness with polyurethane foam (PUF) infilling with a density greater than or equal to 40 kg/m³. The panels must be reinforced along the periphery. Panels must be mounted and secured on suitable tracks. All joints must be sealed with cleanroom compatible neutral grade silicone sealant. All cutouts must be covered with a suitable track.
- III.1.3. **Ceiling:** The cleanroom ceiling must be at a height of 2700 mm or higher from the floor of the cleanroom. The ceiling height of the lab space housing the Class10000 cleanroom is ~5250 mm. The ceiling paneling must be modular, and double skinned with both sheets powder coated (class-10000 clean room grade). The panels must be at least 50 mm thick with PUF infilling with a density greater than or equal to 40 kg/m³. The panels must be reinforced along the periphery and mounted on suitable tracks. All joints must be sealed with cleanroom compatible neutral grade silicone sealant. All cutouts must be covered with a suitable track.
- III.1.4. **Surface Finish of Negative Pressurized Plenum:** The inner surface of the true ceiling & wall surface above false ceiling (negative pressurized plenum) shall be provided with cladding of 25 mm/50 mm thick cleanroom compatible cladding material having PUF as infill material.

- III.1.5. **Flooring:** The flooring must be anti-skid, hard wearing and electrostatic dissipative and sufficiently thick and dense to bear the weight of equipment.
- III.1.6. **Covings:** PVC covings must be installed at corner joints of (a) Wall – Wall (b) Wall – Ceiling (c) Wall – Floor. All 3D corners must be installed and must be covered by 3D pieces. All covings must be ESD proof.
- III.1.7. **Doors:** One double shutter door (D1 in Figure 5) spanning over width 1.8m (each door 0.9m wide) and 2.1m height (to be used for equipment movement and to serve as an emergency exit). All doors must be at least 44mm thick with PUF infill (density > 40kg/m³). The doors must be flush with the panels when closed and must be fixed to the door frames with concealed stainless-steel double bearing butt-hinges as per BS7352 specification. The doors must be provided with all ancillaries like door closer, lock and key, D-handle, push plate, tower bolt all made of SS. Each door must be provided with a view glass of size 0.4m x 0.4m. All doors must open to the outside of the cleanroom and must be provided with a panic bar so that the doors be can quickly opened to exit the cleanroom in the case of an emergency. One door is to kept closed during normal operations. The other door is meant for personnel access to the cleanroom and is to have an access control system.
- III.1.8. **Access control:** A biometric-based access system should be included. This should be configurable for multiple users.
- III.1.9. **Air curtains:** Air curtains must be provided near the door D1 for preventing entry of particles from outside the cleanroom while the doors are opened.
- III.1.10. One safety eye shower must be provided inside the cleanroom at a suitable location.
- III.1.11. This clean room space must include necessary lighting and electrical panels and distribution points, an air handling unit, and a fumehood.

III.2. Lighting and Electrical installations for Class-10000 cleanroom section

- III.2.1. Sufficient ultra-violet-filtered, ceiling mounted LED lighting must be provided through-out the cleanroom. All radiation below 500nm must be blocked by the UV filters in the lighting systems. The lighting must be sufficient to provide 400 lux or greater illumination at 1 m from the cleanroom floor at all points inside the cleanroom. The illumination intensity must be demonstrated before commissioning. The lighting controls must be provided at user accessible locations inside the cleanroom near the user access door. The necessary fittings, wiring from distribution board and switches must also be supplied and installed.
- III.2.2. In addition, UV filter films must be applied at all points where light containing sub 500nm radiation might enter the cleanroom e.g. windows and door vision panels.
- III.2.3. 40 numbers 5/15A single-phase power points, 2 numbers 3-phase, 32A power points. These power points must be distributed over 5 lines each equipped with a suitable rated terminal circuit breaker (MCBs). Each of the power point must be labelled to indicate the line it is connected to. The MCBs are to be housed in a separate power distribution board. The distribution board must be constructed out of cleanroom compatible materials.
- III.2.4. All motors and switchgears required for various items shall generally be all electric. Motors shall be suitable for 3 Phase, 50 Hz, 415 volts A.C. supply. The AC supply variability could be between +/- 10%. Therefore, the motors should

withstand such load fluctuations. If the motor input is not suitable for power fluctuations, a voltage stabilizer should be provided. Electrical supply from electrical panel to respective AHUs/Condensing Units/Dehumidifier must use armored cables. Any underground cabling must be steel armored.

- III.2.5. All electrical wiring/cabling must be fire retardant and of a reputed make and must be sufficiently rated to handle the specified loads. The wiring/cabling must be routed through fire-retardant electrical conduits. Inside the clean room, the cables must be routed through appropriately sized fire-retardant PVC dado with partitions for routing cables and positioning power points separately.
- III.2.6. A suitably rated electrical panel must be provided and cables from AHU and other electrical units must be terminated at the panel. Copper lugs should be insulated for cable termination. All bus bars in the panel should be of copper. Incoming cabling termination at the electrical panel will be provided by IISc.
- III.2.7. All wires/cables must be color coded according to applicable electrical wiring standards. The wires must be labelled appropriately at the terminals. All electrical wiring diagrams/drawings with corresponding labels must be provided with installation documents.

III.3. Installation of gas lines and accessories for Class-10000 cleanroom

- III.3.1. Gas distribution lines for ultra-high pure Nitrogen, ultra-high pure Argon and ultra-high pure 5-10 % Hydrogen-in-Argon gas mixture must be installed. Each gas line must be plumbed from a gas storage bay outside the cleanroom and terminated at a gas manifold inside the cleanroom with at least 4 output lines. The cost of fittings and piping up to 5 meters per gas line must be included in the scope of work. Additional cost for laying gas distribution lines must be quoted on per foot basis. However, the vendor is advised to visit the site and make appropriate measurements/calculations. Failure to do so will not absolve the vendor of responsibility to do the work as specified in agreement.
- III.3.2. The vendor must quote for supply and installation of components for connecting the gas lines to gas cylinders described as follows. Each gas line must have a flexible high-pressure SS hose (SS316L core and SS wire braided outer layer) connected with a bull nose appropriate for each gas mentioned in section III.3.1. The bull nose must be connected to the hose through a non-return valve. The SS hose must be connected to a gas pressure regulator through a shut-off valve. The regulator must be of all stainless-steel construction capable of handling inlet pressure of 200 bar. Outlet pressure must be adjustable over 0-15 bar. A sample configuration is shown in figure 6. The regulator must be of barstock type with SS316L/Hastelloy diaphragm from a reputed OEM. All sealing materials used inside the regulators/shut-off valves must be compatible with the particular gas type and purity grades. The vendor must attach datasheets/specifications for the same.
- III.3.3. The plumbing for nitrogen gas lines from the gas manifold to the fume hood specified in section III.5 is to be included in the quote on per foot basis. The plumbing of UHP-Argon and 5-10 % Hydrogen-in-Argon gas mixture lines from the gas manifold up to a glovebox housed inside the clean room to must be quoted on a per foot basis.
- III.3.4. Gas tubing must be supported on channel mounted tubing support with provision to carry a total of 5 lines.

- III.3.5. Any unconnected lines must be appropriately terminated with suitable fittings.
- III.3.6. All support structures and fittings inside the cleanroom must be resistant to acids and common organic solvents.
- III.3.7. All gas lines and accessories must be constructed out of high quality SS316L and must be of a reputed make. Orbital welding or VCR type metal-metal seals are preferred for all joints and fittings on the gas distribution lines. Compression type seals are also acceptable, if compatible with clean room specifications. The RMS roughness of the inner body of the SS tubing must be compatible with the gas type as mentioned in III.3.1.
- III.3.8. Shut off valves are to be provided for every point of use connection.
- III.3.9. All gas lines must be leak-checked after installation and appropriate connections.
- III.3.10. All gas lines must be labelled at appropriate intervals with clearly visible fade-proof labels easily readable by the user. The vendor must also provide drawings of the final gas plumbing layout.

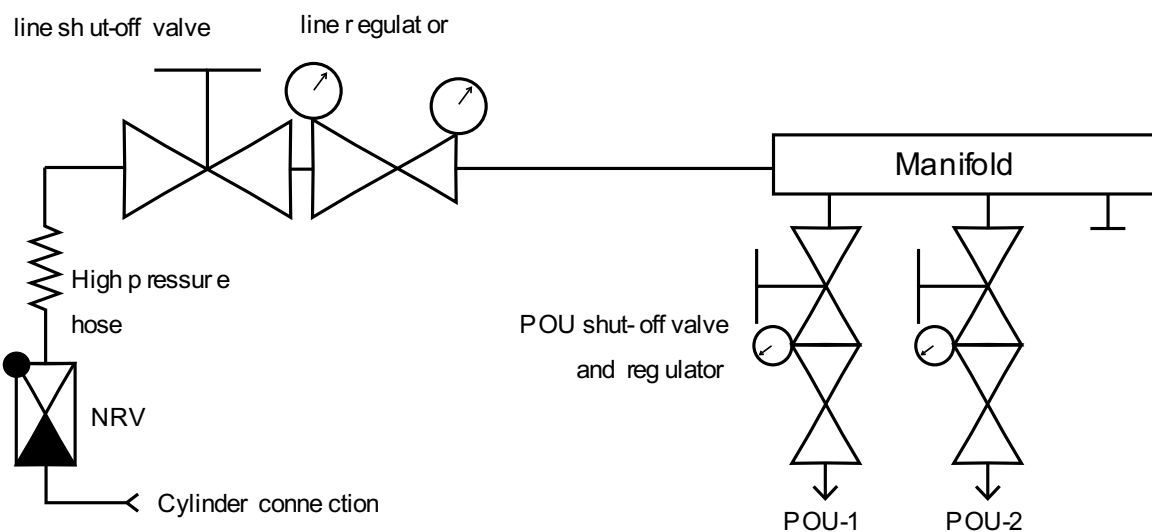

Figure 6: Sample gas line configuration

III.4. Air Handling Unit and related specifications for Class-1000 cleanroom section

- III.4.1. A dedicated recirculating type Air handling unit/HVAC system must be provided for the class-10000 cleanroom
- III.4.2. The HVAC system must be designed to maintain the class-10000 clean room conditions as specified below:
 - 1) Air purity: Particulate concentration of less than 10000 particles per cubic feet (Class-10000) according to ISO 14644
 - 2) Room temperature of 22 ± 2 °C
 - 3) Relative humidity levels (RH) of $45 \pm 5\%$
 - 4) Differential pressure of 15-20 Pa
 - 5) Number of users: **five** users
 - 6) Estimated equipment load: 20 kW.
 - 7) Air flow pattern: Downward unidirectional
 - 8) Supply air plenum: Negative pressure plenum type airflow using FFU with suitable HEPA filters.

- 9) Supply air change rate: 60 air changes per hour
 - 10) Supply air velocity: minimum 90 fpm $\pm 20\%$ (0.45 mps $\pm 20\%$)
 - 11) Filter coverage: minimum 15%
 - 12) Fresh air changes per hour: 3
- III.4.3. Modular fan filter units (FFUs) mounted on the cleanroom ceiling filter the air and blows it into the cleanroom through suitably rated HEPA filters to remove particulate contaminants. The return air is extracted through side extractors near the floor through the enclosed air-raisers inside the wall panels. Part of the return air is conditioned and filtered in the Air Handling Unit (AHU) where the air passes through a series of pre/fine filters, cooling/reheating coils before being supplied to the FFU through corrosion resistant, insulated ducting. The suggested airflow schematic is shown in figure 3. Any other airflow designs, if submitter must be technically justified.
- III.4.4. The Air Handling Units (AHU) must be designed to meet specifications in III.4.2. Fresh air intake must also take into account the exhaust of the fume hood specified in section III.5. The AHU must be fitted with appropriate cooling coils, humidifiers, dehumidifiers, pre-filters etc. required to maintain the air temperature and humidity within specification III.4.2. The condenser unit must have a capacity of 6 TR or greater. The air heater module must also be appropriately rated. Only non-toxic, environment friendly refrigerants (R-407C or equivalent) may be used in the condenser units. Details of the refrigerant must be provided. All refrigerant piping and connectors must be made of copper and suitably insulated.
- III.4.5. Treated fresh air needs to be provided in order to compensate for any losses and also to maintain spatial positive pressure in the cleanroom. Precooling coils with suitable pre filters, volume control dampers (VCDs), mixing box, heaters, mist eliminators etc. shall be provided for the fresh air intake of the AHU.
- III.4.6. AHU must be installed on the roof of the building that houses the clean room. Approximate length of the ducting required is about 12 meters. The vendor may specify optional per meter cost for any extra ducting work. However, the vendor is advised to visit the site and make appropriate measurements/calculations. Failure to do so will not absolve the vendor of responsibility to do the work as specified in agreement
- III.4.7. Fan filter units (FFU) must be modular in design and must be sourced from a reputed Original Equipment Manufacturer (OEM). Sufficient number of FFUs must be provided to maintain the cleanroom particulate and other specifications (specification III.4.2).
- III.4.8. All filter units must have HEPA filters manufactured by a reputed OEM. The filters must remove particulates bigger than 0.3 micron with 99.997% or greater efficiency (vendor must provide manufacturer specifications or supporting data). The quote must include details of the OEM. The filter units must also be equipped with prefilters to remove particulates bigger than 10 microns with 90% or greater efficiency.
- III.4.9. The FFUs must have variable air flow rate with user controllable fan speed. The minimum flow rate must be 650 cfm. The fan filter units must produce less than 55 dB of noise measured inside the cleanroom at a distance of 750 mm from the filter face. The vibration levels must be less than 25 microns.

- III.4.10. All unit enclosures must have a double skinned corrosion resistant enclosure with a thermal and acoustic insulating infill i.e. PUF of sufficient density. The enclosure must be provided with fire and smoke detectors and alarms, inspection doors and necessary inspection lighting. All mounts and frames for the indoor/outdoor units must be painted, be corrosion resistant and must be suitably padded to minimize vibration and noise.
- III.4.11. All ducting must be fabricated according to the latest SMACNA standards and must be compatible for the cleanroom classification. The air handling ducts and ducting joints must be made of corrosion resistant material that is resistant to any acid vapors and must have a minimum thickness of 24 gauge (~0.635mm) conforming to the latest SMACNA and cleanroom standards. The clause regarding acid resistance may be relaxed for portions, that the vendor has sufficient reason to believe, would never be exposed to acid vapors. However, the vendor must provide suitable drawings/documentation to support this. The ducting must be low noise and vibration free. All ducting/joints must be tested for leakage before commissioning and the leakage must be within the limits specified in the latest SMACNA standards.
- III.4.12. All ducting must be provided with sufficient thickness of insulation. The insulation must be fire retardant and aluminum faced. Provision must be made for internal cleaning of the ducting at appropriate locations.
- III.4.13. Any grills/diffusers used must be made of extruded anodized aluminum.
- III.4.14. All clamps/fastenings used for the ducting must be corrosion resistant.
- III.4.15. Alarms indicating any faults including fire and smoke alarms and alarms for detecting faults in the air handling system must be installed inside the cleanroom to alert users inside the cleanroom in case of any emergencies.
- III.4.16. An indicator/display unit for clean room temperature, RH and air handling system status along with a gauge showing the differential pressure of the cleanroom must be provided inside the cleanroom.

III.5. Specifications for fumehood

- III.5.1. The fumehood is meant for wet chemical processing using organic solvents and de-ionized water and must be provided with an exhaust system.
- III.5.2. The overall dimensions of the fumehood are 1800x800x2400 mm (length x width x height).
- III.5.3. The fumehood must be constructed out of stress relieved high-quality polypropylene sheets of thickness 10mm (data regarding residual stress in the sheets must be provided). Any material being quoted must meet all clean room materials specifications as noted in I.5. In addition, the material should be compatible with a variety of clean room solvents and photoresist/developer solutions used in a clean room. **A list of compatible solvents must be given.**
- III.5.4. The fumehood must be provided with a flat worktop made of 10mm thick polypropylene sheet. A skirting of width 25mm and 10mm height must be provided at the front of the worktop to contain any spills on the worktop and prevent spilling on the floor. It must include a polypropylene sink as specified in section III.5.11. The worktop must be at standard fumehood worktop height from the cleanroom floor.
- III.5.5. A clear transparent height adjustable counter-weight balanced sash made of acid and solvent resistant material that is at least 6mm in thickness. If this is a glass

sash, it should be made of toughened laminated glass so that the glass does not shatter and fall to pieces in case of an explosion or breakage.

- III.5.6. At fumehood must have standard fumehood face opening at full sash position and must maintain a face velocity between 90-110 fpm at half sash position.
- III.5.7. The fumehood exhaust blower must be suitable rated and all ducting must be fire-resistant polypropylene. The quote should include all necessary fittings for routing the exhaust duct and installation of the blower.
- III.5.8. Two Nitrogen guns made of virgin PTFE with anti-static protection must be provided at each end of the fumehood worktop. The nitrogen blow guns must have a filter housing with disposable filters. The piping for each of the guns must have enough length to reach the whole of the work area. When not extended, the extra piping must retract and be concealed inside the workstation body.
- III.5.9. The gas supply lines for the workstation must be done with high-quality stainless-steel tubing from the gas storage bay to the workstation. The piping must be resistant to acids and common organic solvents. The piping for the Nitrogen gun must be flexible, must be resistant to acids and common solvents and must not outgas or generate particulates (provide specifications or manufacturer data sheet).
- III.5.10. A gas line regulator rated at 0-15bar with line and outlet pressure indication and a shut-off valve must be provided on the gas supply line to the control the pressure of the nitrogen at an accessible location near the workstation. The pressure regulators must be all SS construction with a barstock type design. The diaphragm must be made of SS316L or Hastelloy. All fittings must for suitable for pressure gas control of noncorrosive or toxic, high purity gases up to grade 5.0 purity (99.999%).
- III.5.11. A polypropylene sink with 250 x 200 mm must be provided inside the fumehood at back left corner. It must have a polypropylene gooseneck with a tap and connected to the DI water supply line. The drain of the sink must be piped into the building drainage duct.
- III.5.12. Lighting with UV-filtering (provide specifications or manufacturer data sheets) for an illumination level of 1000 lux or greater at worktop level on all points of the worktops, in the fume hood and the clean bench sections, should be provided.
- III.5.13. Magnehelic gauge of 50mm of water column capacity to measure the differential pressure at the exhaust plenum box in part-1 (fume hood) of the workstation must be provided.
- III.5.14. Two storage cabinet trolleys of 900mm length each for chemicals/materials storage under fumehood. The trolleys must be made of high-quality polypropylene.

IV. List of approved manufacturers

Any one of the following makes of equipment/components/items are acceptable to the company subject to meeting the technical specifications specified in the tender. Please note that any other makes which are specified as EQUIVALENT should be approved in writing by IISc after submitting required sample and/or technical specification sheets as required

IV.1. Cleanroom construction

Description of items	Approved makes
Air Curtain for class-10000 clean room entrance	ALMONARD/ FABTECH/ I-CLEAN
Wall panels, Ceiling panels and mounting systems	PLASCORE / CHANNEL SYSTEMS/ VEROVERIA/ RITTERWAND/ FLEXICON/ AMERICAN CLEANROOM SYSTEMS
UV filter films for door vision panels and windows	UV PROCESS SUPPLY USA/ DURXTREME GMBH/ ASMETEC GMBH
Antistatic vinyl flooring tiles	FORBO/ STATCLEAN/ TARKETT/ WONDERFLOOR/ GERFLOR/ DOY YEE
RH and temperature indicator	WAREE/ HTA
Magnahelic gauge	WAREE/ DWYER/ SENSOCON
Emergency eye wash	KLENZAIDES/ I-CLEAN/ GMP/ CRP/ FABTECH

IV.2. Air handling systems

Description of items	Approved makes
Air Handling Units	EDGETECH/ ZECO/ SYSTEMAIR/ FLAKTWOOD/ CITIZEN/ I-CLEAN
AHU Fan blower	NICOTRA/ KRUGER/ FLAKTWOODS
Motors for AHU	CROMPTON GREAVES/ ABB/ SIEMENS /KIRLOSKAR (motors shall be the highest star rated category as per bee)
Motor Soft starter	SIEMENS/ ABB/ L&T/ SCHNEIDER
Fan Filter Units/HEPA filters for Class-1000 and Class-10000	CAMFIL/ AAF/ CFS/ FREUDENBERG/ EGCLEANTECH/ UNIFIL
Chiller unit	YORK/ CARRIER / TRANE/ CLIMAVENTA

Chiller Motors	ABB/ SIEMENS/ CROMPTON GREAVES
Chilled / Condenser Water Pipes	SAIL/ TATA/ JINDAL
Globe Valve/ Gate Valve/ Check valve	CASTLE/ ADVANCE/ AUDCO/ ALFA LAVAL/ LEADER
Butterfly Valve	AUDCO / L&T/ KIRLOSKAR/ ADVANCE/ BELIMO/ CASTLE
3 Way Control/ Mixing Valve	HONEYWELL/ SIEMENS/ BELIMO
Balancing Valves/ Flow Measuring devices	BELL & GOSSETT/ TOUR & ANDERSON/ ANERGY/ SIEMENS/ ADVANCE
Water flow Switch	HONEYWELL/ SIEMENS/ BELIMO
Ducting – GI sheets	SAIL / JINDAL / TATA
Flexible duct	ATCO/ GP SPIRO/ ROLASTAR
Duct Insulation	ARMAFLEX/ K- FLEX/ SUPREME/ TROCELLENE/ ARMACELL
Magnehelic gauges	WAREE/ DWYER/ SENSOCON
Damper Actuators	HONEYWELL/ SIEMENS/ BELIMO
Grilles/ Diffusers/ VCD/ Ducting fittings	AIR MASTER/ CARYAIRE/ AJANTA/ SYSTEM AIR / FLAKTWOOD/ COSMOS/ RUSKIN TITUS
Temperature/ RH/ Pressure Sensors (Cleanroom)	HONEYWELL/ SIEMENS/ JOHNSON
Pressure gauges	WIKA/ FORBES MARSHALL
RH and temperature indicator	WAREE/ HTA
Thermostats/ Humidistat	SAUTER/ SIEMENS/ JOHNSONS/ HONEYWELL
Dehumidifiers	BRY-AIR/ MUNTERS/ WHITE WASHINGHOUSE/ APPIDI/ AIR PACK
Pan type humidifier	RAPID COOL/ NORDAMANN/ WALTER MEIER/ APPIDI/KEPL
Electrical Strip Heaters	HEATCON/ DASPASS/ ESCORTS/RAPID COOL/KEPL
Electrical LT Panels as per IEC 61439-1	LEGRAND/ SCHNEIDER ELECTRIC / SIEMENS / ABB /L&T or their authorized franchisees/ system integrators
MCCB	SIEMENS/ SCHNEIDER/ ABB / L&T / LEGRAND

MCB	SIEMENS/ SCHNEIDER/ ABB / L&T / CG / HAGER / INDO ASIAN
Power/ Control Contacts, Overload Relays, Timers, etc.	SIEMENS/ SCHNEIDER/ ABB / L&T
Fuses	SIEMENS/ SCHNEIDER/ ABB / L&T
Power Cables/ Control Cables/ Wires	FINOLEX/ UNIVERSAL/ POLYCAB/ UNISTAR/ NICCO / RAVIN

IV.3. Fumehood/ Wet chemical station

Description of items	Approved makes
Blower motors for fumehood, ductless fumehood, cleanbench etc.	CROMPTON GREAVES/ ABB/ SIEMENS /KIRLOSKAR (Motors shall be the highest star rated category as per bee)
Fan Filter Units/HEPA filters for Class 100 clean benches	CAMFIL/ AAF/ CFS/ FREUDENBERG/ EGCLEANTECH/ UNIFIL
Magnehelic gauges	WAREE/ DWYER/ SENSOCON
Uniform temperature hot plate	WENESCO
Spin Coater	LAURELL
Gas pressure regulator	SWAGELOK/ GCE/ SANDVIK/ VALEX/ DOCKWEILER
Gas Piping and fittings	SWAGELOK/ GCE/ SANDVIK/ VALEX/ DOCKWEILER

IV.4. Gas piping

Description of items	Approved makes
SS tubing	SWAGELOK/ GCE/ SANDVIK/ VALEX/ DOCKWEILER
Regulators	SWAGELOK/ MATHESON/ GCE/ HALEHAMILTON/ MESSER
Valves	SWAGELOK/ MATHESON/ GCE/ VALEX, TK-FUJIKIN/ DOCKWEILER
Fittings, flexible high-pressure hoses, tubing mounts etc.	SWAGELOK, MATHESON, GCE, DOCKWEILER

IV.5. Lighting and electrical

Description of items	Approved makes
Lighting – LED	PHILIPS /OSRAM
Electrical LT Panels as per IEC 61439-1	LEGRAND/ SCHNEIDER ELECTRIC / SIEMENS / ABB /L&T OR THEIR AUTHORIZED FRANCHISEES/ SYSTEM INTEGRATORS
MCB distribution boards	LEGRAND, SIEMENS, CROMPTON, HAVELLS
LT cables	NICCO/UNIVERSAL/ FINOLEX
Power Cables/ Control Cables/ Wires	FINOLEX/ UNIVERSAL/ POLYCAB/ UNISTAR/ NICCO / RAVIN
Electrical conduits	POLYCAB/ AVONPLAST / SUDHAKAR/ PRECISION/AKG
Switches/sockets	ANCHOR/ MK/ LEGRAND/ ABB/CRAB TREE/ SCHNEIDER ELECTRIC
MCBs	SIEMENS/ SCHNEIDER/ ABB / L&T / CG / HAGER / INDO ASIAN
MCCB	SIEMENS/ SCHNEIDER/ ABB / L&T / LEGRAND

IV.6. De-ionized water system

Description of items	Approved makes
DI water system	EVOQUA WATER TECHNOLOGIES/ MILLIPORE /KOMAL / GRAUER &WEIL, / PURELAB-ELGA /

IV.7. Safety and access control

Description of items	Approved makes
Fire/smoke detection and alarm systems	NOTIFIER / SIEMENS / GE / APOLLO (UL CERTIFIED ONLY)
Safety Eye Shower	PAL BAM / TERRA UNIVERSAL /NUAIRE/ CLEAN ZONES /ROTH
Access control and emergency systems	SIEMENS / BOSCH / HONEYWELL

V. Terms and conditions

- V.1. The vendor is responsible for the installation and commissioning of the cleanroom and all utilities/equipment covered under the contract.
- V.2. The electrical system installation shall be carried out by qualified electricians either employed or contracted by the vendor.
- V.3. The vendor must arrange for materials unloading and staging.
- V.4. The vendor must demonstrate that the performance and quality parameters of the cleanroom and equipment comply to the specifications. Following performance tests must be carried out at three occupancy states: as-built, at-rest, and operational.
 - a) Air-borne particle count for ultrafine particles
 - b) Airborne particle count for macro-particles
 - c) Airflow test, air velocity measurement, leakage test, room pressurization test
 - d) Air pressure difference test
 - e) Temperature test
 - f) Humidity test
 - g) Illumination level measurement according to DIN 5035
 - h) Recovery test
- V.5. The vendor shall supply cleanroom certifications complying with ISO 14644 requirements.
- V.6. The price quotation should include the cost of installation and training of potential users.
- V.7. The system should be provided with at least **3-years of warranty**, on all parts and labor, from the date of installation.
- V.8. The vendor must provide routine maintenance of the cleanroom and associated equipment that is part of this tender.
- V.9. The vendor should have a track record of having previously supplied and installed at least five cleanroom systems in India with similar specifications. Details of such systems should be provided.
- V.10. The vendor should have qualified technical service personnel for the equipment based in India and should assure a response time of less than 48 hours.
- V.11. Vendor must provide a user list (with contact details including emails and phone numbers) of at least 5 customers from Indian Institutes/Labs where similar systems have been installed.
- V.12. The lead-time for the delivery of the equipment should not be more than 6 months from the date of receipt of our purchase order.
- V.13. The indenter reserves the right to withhold placement of final order. The right to reject all or any of the quotations and to split up the requirements or relax any or all of the above conditions without assigning any reason is reserved.
- V.14. Wherever requested data must be supplied along with technical compliance documents. Technical bids without supporting data will be deemed as technically non-compliant.
- V.15. All guaranteed specifications may have to be demonstrated at the time of installation. Any necessary standard samples for that purpose should be brought by the service engineers.
- V.16. Printed literature and published papers in support of all compliance to the prescribed specifications may be provided.

- V.17.* The vendor **must provide compliance statement** in a tabular form with respect to each technical specification in the tender document duly supported by the manufacturer's literature and published papers. Any other claim will not be accepted and may lead to rejection of the bid.
- V.18.* Technical evaluation by the institute may include demonstration to verify functionalities and capabilities of the system quoted. Any discrepancy between the promised specifications and measurements will be deemed as technical non-compliance.
- V.19.* The vendor must quote for a non-comprehensive AMC price beyond the 3-year warranty period, with a price lock in for 2 years beyond the standard 3-year warranty period. 2 services per year should be included in the AMC.
- V.20.* The quote should also include additional spares sufficient for three years of system usage assuming an average usage of 120 hours of operation per week.